

MANUAL



**SOHARD**  
EMBEDDED SYSTEMS

# SH ARCALYZER

ARCNET Network Analyzer  
Incl. Interface Module

Copyright by SOHARD Embedded Systems GmbH, all rights reserved  
V 03.00



## Table of Contents

1. Overview .....	3
2. Software .....	4
2.1 System Requirements .....	4
2.2 Installation .....	4
2.2.1 WINDOWS NT 4.0 .....	4
2.2.2 WINDOWS 2000 .....	5
2.3 Software Functions.....	5
3. Features at a Glance .....	6
4. Functions.....	7
4.1 Access .....	7
4.2 Connections .....	7
4.2.1 Interface Module .....	7
4.2.2 Extension Port.....	7
4.3 LEDs on Interface Modules .....	8
4.4 Settings for Interface Modules.....	8
4.4.1 Coax interface module .....	8
4.4.2 RS485 Interface Module.....	9
4.4.3 Fibre Optics Interface Module .....	10
5. Interfaces .....	11
5.1 Coax Interface.....	11
5.2 RS485 Network Interface (9 pin socket) .....	11
6. Technical Data .....	12
6.1 General .....	12
6.2 ARCNET Functionality.....	12
6.3 Interface Modules.....	12
6.3.1 Coax Interface Module .....	13
6.3.2 RS485 Interface Module (9 pin socket) .....	13
6.3.3 Fibre Optics Interface Module .....	13
7. CE Declaration of Conformity .....	14
8. Support.....	15
8.1 Contact Addresses .....	15
9. Literature .....	15
10. Warranty .....	16
11. Index.....	17

## 1. Overview

The SH ARCALYZER is a universal and extremely efficient network analyzer for ARCNET networks with bit rates from 19 Kbps to 10 Mbps.

It consists of a special PCMCIA card and an interface module to connect to ARCNET networks via coax, RS-485 or fibre optic cables as well as software for WINDOWS NT 4.0 and WINDOWS 2000.

Common ARCNET analyzers normally use ARCNET controller chips such as COM 20020. Those offer only limited possibilities. SH ARCALYZER, however, uses specially developed hardware. A 1 Mbit large buffer (FIFO) on the card ensures that no data will be lost with non-real time operating systems such as WINDOWS NT, or with very high data flow.

Thanks to fully re-configurable logic (FPGA) the SH ARCALYZER is simply updated with software to add additional functions. Thus the SH ARCALYZER is future proof!

Ordering index as follows:

Order Name	Description
SH ARCALYZER	PCMCIA Card with software and any interface module (please specify)
SH KOAX-PCMCIA	Interface module for Coax cable, BNC plug, 2,5 Mbit/s
SH KOAX-PCMCIA-10	Interface module for Coax cable, BNC plug, 5 and 10 Mbit/s
SH RS485-PCMCIA-10	Interface module, RS485 with 9-pol Sub-D plug, max. 10 Mbit/s
SH LWLST-PCMCIA	Interface module for Fibre Optic connection with ST plug, max. 2,5 Mbit/s
SH LWLSMA-PCMCIA	Interface module for Fibre Optic connection with SMA plug, max. 2,5 Mbit/s

All interface modules feature aluminium housing.

## 2. Software

### 2.1 System Requirements

(Minimal) Requirements for Host Computer:

Operating System	WINDOWS NT 4.0 or WINDOWS 2000
Memory	64 MB RAM
Processor	Pentium (or equivalent) with 133 MHz
Monitor Resolution	800 x 640 Pixel
HTLM Browser	Internet Explorer by Microsoft, V04.00 or higher
Free Hard Disk Space	10 MB

We recommend 128 MB RAM or more and a monitor resolution of 1024 x 768 or higher. For use of the SH ARCALYZER in nets with bit rates of 5 Mbps or more we recommend a Pentium III CPU (or equivalent) with 400 MHz or more.

### 2.2 Installation

The included software consists of a driver for the hardware and the analyzer software. In the following chapters we describe the installation of both components.

#### 2.2.1 WINDOWS NT 4.0

- Put the included CD in CD ROM drive.
- Install the included PCMCIA card in one of the free PCMCIA slots of type 2 or 3.
- Execute SETUP.EXE on CD.
- Just follow SETUP instructions.

Re-boot computer after installation before using the SH ARCALYZER.

*Please observe that the PCMCIA card must already be installed when you start WINDOWS NT 4.0 to fully use the SH ARCALYZER.*

### 2.2.2 WINDOWS 2000

- Put included CD into CD ROM drive.
- Install included PCMCIA card in free PCMCIA slot of type 2 or 3.
- WINDOWS 2000 recognizes the new hardware and starts the hardware wizard.
- Follow instructions of hardware wizard.
- Then execute SETUP.EXE on CD.
- Follow instructions of SETUP program.

Now you can fully use the SH ARCALYZER.

Please, never remove PCMCIA card while the SH ARCALYZER program is running.

## **2.3 Software Functions**

The online help describes the software functions.

### 3. Features at a Glance

- PCMCIA Bus
- Mapping of registers in I/O address range of host
- SRAM based FPGA (Field Programmable Gate Array) for analyzer logic
- 1 Mbit SRAM for buffer
- COM20022 Controller (for future expansions)
- 1 plug for MAU connection
- 1 plug for future expansions

#### **RS485 Interface Module**

- 9 pin Sub-D connector
- Optically decoupled
- Bitrate DC - 10 Mbit/s
- Integrated termination activated via DIP-Switch
- Protective circuit
- LED (green) for display of ARCNET activity
- LED (red) for display of host accesses
- aluminium casing

#### **Coaxial Interface Module**

- BNC connector
- Suits RG 62 Coax cables (93 ohms of impedance)
- Bitrate 2.5 Mbit/s (optional up to 10 Mbit/s)
- Protective circuit
- Protects coaxial transceiver from wrong access
- LED (green) for display of ARCNET activity
- LED (red) for display of host accesses
- aluminium casing

#### **Fibre Optics Interface Module**

- Bitrate DC - 2.5 Mbit/s
- SMA or ST - connector available
- Selects optical output power in 4 steps
- LED (green) for display of ARCNET activity
- LED (red) for display of host accesses
- aluminium casing

Information about additional interface modules available under <http://www.sohard.de>

## 4. Functions

### 4.1 Access

Address the SH ARCALYZER PCMCIA card via I/O. The interrupt and IO-address are automatically allocated by "Card services". No manual setting is required.

### 4.2 Connections

#### 4.2.1 Interface Module

Connect the interface module – which is the connection to ARCNET – at the 'interface module' – plug.

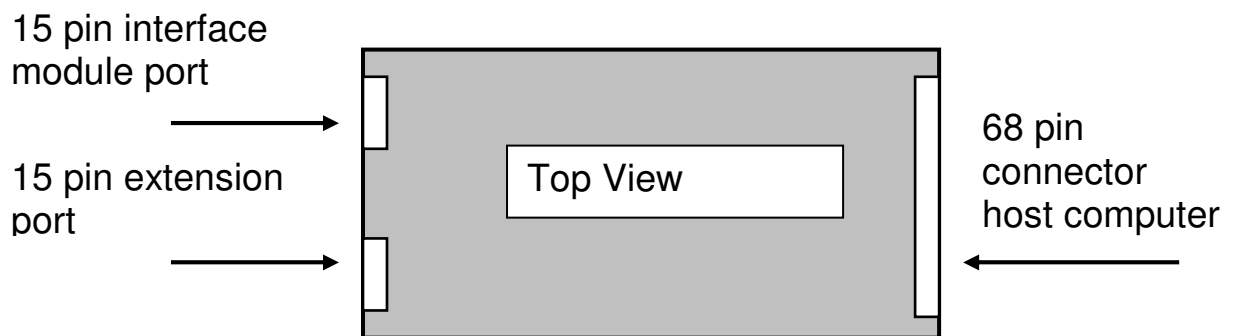

#### 4.2.2 Extension Port

The Extension Port is available for future hardware expansions.

### 4.3 LEDs on Interface Modules

#### LED (green):

The LED reports all activity on the ARCNET<sup>®</sup> receiving channel. The signal is extended and thus made visible via a digital mono-stable multi-vibrator. If the ARCNET<sup>®</sup> runs in a stable state, the LED is continuously active. If reconfigurations [1] are performed, the LED flickers periodically.

#### LED (red):

The LED reports all write/read access by host PC to the SH ARCALYZER PCMCIA card. Every access is extended and thus made visible via a digital mono-stable multi-vibrator (time constant approx. 1 msec).

### 4.4 Settings for Interface Modules

#### 4.4.1 Coax interface module

A DIP switch S1 turns on/off the termination (93 Ohm). For that the casing must be opened. The module is shipped with termination disabled.

Dipswitch S1

Switch 1	Switch 2	Function	Remark
ON	ON	Termination activated	
<b>OFF</b>	<b>OFF</b>	<b>Termination not activated</b>	<b>Default</b>
ON	OFF	Not allowed	
OFF	ON	Not allowed	

#### 4.4.2 RS485 Interface Module

The termination can be turned on or off on the module via DIP-switch S1. When shipped termination (effective impedance of approx. 115 ohm) is not activated. To activate it open the casing. The impedance of the cable used should meet that value as close as possible to avoid any reflections.

##### Dipswitch S1

Switch 1	Switch 2	Function	Remark
ON	ON	Line termination activated for RS485	
<b>OFF</b>	<b>OFF</b>	<b>line termination not activated for RS485</b>	<b>Default</b>
ON	OFF	invalid	
OFF	ON	invalid	

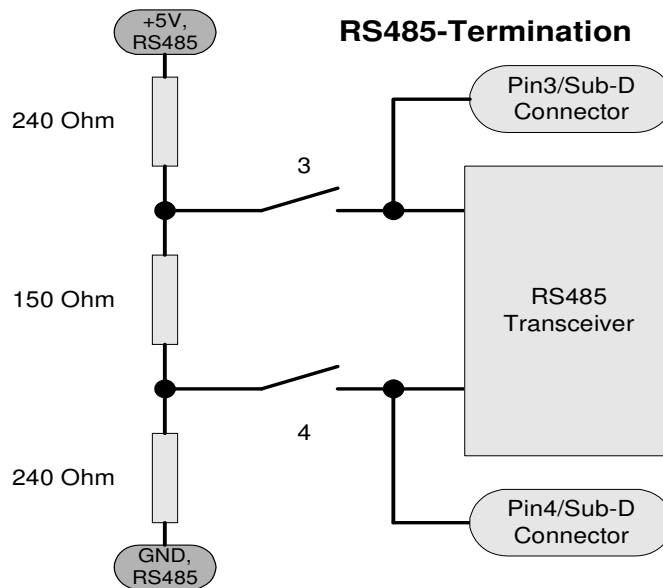

The interface can work with all transmission rates.

**Important note: to maintain CE compliance, the cable connection to the Sub-D connector must have a shield that connects to the plug at lowest possible impedance.**

#### 4.4.3 Fibre Optics Interface Module

Set the optical output power of the transmitter in 4 steps. For that, open the casing. We recommend low power for short distances and fiber optic cables with low attenuation (< 3db/km) to avoid overload on optical receiver. For greater distances and/or cables with higher attenuation select medium or high power settings.

#### Dipswitch

S1	S2	Opt. output power	Remark
OFF	OFF	very low	
<b>OFF</b>	<b>ON</b>	<b>Low</b>	<b>Default</b>
On	OFF	Medium	
ON	ON	high	

#### Note:

The 'send functions' of the fiber optic module are only necessary when the software supports the operation of the integrated ARCNET Controller COM20022 for transmitting data packets.

## 5. Interfaces

### 5.1 Coax Interface

Plug type: BNC connector, insulated

#### Pinout:

PIN	Name	Meaning
1	Shield	outer conductor coaxial cable
2	Center	inside conductor coaxial cable

### 5.2 RS485 Network Interface (9 pin socket)

This pinout is upward compatible to the FARC E3 card by SoHard

Plug type: SUB-D, 9 pin, male

#### Pinout:

PIN	Name	Meaning
1	GND_RS	data reference potential, ground supply voltage
2	nc	reserved
3	Data A	data line A (in idle state more positive than DATA B)
4	Data-B	data line B (in idle state more negative than DATA A)
5	GND_RS	data reference potential, ground supply voltage
6	nc	reserved
7	nc	reserved
8	nc	reserved
9	+5 V_RS	dc decoupled 5 volts for RS485 interface. The peak voltage must not exceed 25 mA.
shield	PE	shield or system-unit cover potential

PE is slot metal resp. system-unit cover potential. GND\_RS ground dc-decoupled RS485 circuitry element.

## 6. Technical Data

### 6.1 General

Power Supply:	+5V, max. 0,2A (w/o interface module)
Temp. range operation	0 °C to +55 °C
Temp. range storage:	-20 °C to +85 °C
PCMCIA Bus functionality	PCMCIA Spec V2.1
Interrupts:	IRQ 9(2),3,4,5,6,7,10,11,12,14,15
Dimensions:	width ca. 54 mm, height ca. 5 mm, depth 86 mm acc. to PCMCIA Spec V2.1 Type 2
weight:	max. 0,2 kg with packaging

### 6.2 ARCNET Functionality

Compatibility:	ANSI/ATA 878.1[2]
Data rates:	19.5/39.1/78.1/156.3/312,5/625kbps, 1,25/2,5/5/10 Mbit/s

### 6.3 Interface Modules

For all interface modules:

Operating Temperature Range:	0 °C to +55 °C
Storage Temperature Range:	-20 °C to +85 °C
Connection to SH ARC-PCMCIA:	shielded cable , approx. 15 cm length
Dimensions without connectors:	width 55 mm, height 23 mm, depth 102 mm
Casing material:	aluminium

### 6.3.1 Coax Interface Module

Power supply:	+5V, < 600mA
Transmission rate:	2.5 Mbps (SH KOAX-PCMCIA) or 5/10 Mbit/s (SH KOAX-PCMCIA-10)
Input impedance:	$\geq 1$ kOhm (at $f = 5$ MHz)
Output voltage:	min. 16 Vss at terminated 93 ohms line
Output pulse:	sine di-pulse 200 ns to ANSI/ATA 878.1 (50 ns at 10 Mbit/s)
Wiring:	RG62 with $Z = 93$ ohms is recommend
Connector:	insulated BNC socket

### 6.3.2 RS485 Interface Module (9 pin socket)

Power supply:	+5V, < 400mA
Transmission rate:	DC to 10 MBit/s
Input level threshold:	+/- 200 mVs
Polarity idle level:	positive
Input impedance:	set via DIPswitch approx. 120 ohms (with DC biasing)
DC biasing:	set via DIP switch 240 ohms +5 V/240 ohms 0 V
Transmission level:	min +/- 3.0 V
Connector:	SUB-D connector, 9 pin, male

### 6.3.3 Fibre Optics Interface Module

Power supply:	+5V, < 200mA
Transmission rate:	DC to 2.5 MBit/s
Optical input power: (receiver)	min. -25.5 dBmW, max. -9.2 dBmW
Optical output power: (transmitter)	type. -14 dBmW with 50 $\mu$ m fiber optic cable @setting "high".
Wavelength Max. emission:	820nm
Connector:	2 x SMA or 2x ST
Fiber optics:	50/125 or 62.5/125 or 100/140 $\mu$ m

## 7. CE Declaration of Conformity

### EC Declaration of Conformity



EC Declaration of Conformity  
in accordance with Annex IV of Directive 2004/108/EC

*Name of Supplier:* **SOHARD  
Embedded Systems GmbH**

*Address of Supplier:* **Würzburger Str. 197  
D-90766 Fürth  
Germany**

declares that the present product

*Product name:* **SH ARCALYZER**

of one of the following types

*Product type:* **SH ARCALYZER  
SH ARCALYZER incl. Extender Box**

meets the requirements of Directive 2004/108/EG of the European Parliament and of the Council as specified in Annex I of the said Directive. In accordance with Article 6 of the said Directive this Declaration is based on the following harmonized Standards

*Safety:* **EN60950: 1992  
+ A1: 1993 + A2: 1993  
+ A3: 1995 + A4: 1997**

*EMC:* **EN 50081-2: 1994-03  
EN 50082-2: 1997-11**

Fürth, 13.06.2008

A handwritten signature in black ink, appearing to read 'S. Schnitzenbaumer', is written over a horizontal line.

(Sebastian Schnitzenbaumer, Managing Director)

## 8. Support

In case you have problems using the card, please check all settings again and note software version, driver and hardware before you contact us (see menu point ,Info'). Thank you.

### 8.1 Contact Addresses

SOHARD Embedded Systems GmbH  
Würzburger Str. 197  
90766 Fürth  
Deutschland

Tel: +49 (0)911 97341 - 0 (Switch Board)  
- 522 (Technical Support)

Fax: +49 (0)911 97341- 510

eMail: [arcnet@sohard.de](mailto:arcnet@sohard.de)

Latest software, drivers, manuals and technical info to this product available under [www.sohard.de](http://www.sohard.de) .

## 9. Literature

Reference	Document
[1]	Data Sheet COM20022B, SMSC ( <a href="http://www.smcs.com">http://www.smcs.com</a> )
[2]	ANSI/ATA 878.1 Local Area Network: Token Bus (2.5 Mbps), ATA 1992, <a href="http://www.arcnet.com">http://www.arcnet.com</a>

## **10. Warranty**

Warranty is granted by SOHARD Embedded Systems GmbH according to our General Terms and Conditions.

## 11. Index

---

### **A**

ANSI 12, 15  
ARCNET-functionality  
12  
ATA 878.1 13, 15  
ATA 878.1 12

---

### **C**

CE Conformity 10  
Coax interface 11  
COM20022 15  
Compatibility 12  
Contact Addresses 15

---

### **D**

datarate 12  
datasheets 15  
dimensions 12  
Download 15

---

### **E**

eMail 15

Extension Port 7

---

### **F**

fibre optics interface  
module 6  
FPGA 6

---

### **I**

Interface Port 7  
Interrupts 12

---

### **L**

LED 8

---

### **O**

online help 5  
Optical output power  
13  
Optical power setting  
10  
ordering index 3

---

### **R**

Reference documents  
15

---

### **S**

setup 4  
Shield 10  
storage 12  
Support 15

---

### **T**

Technical Support 15  
Termination 9, 10

---

### **W**

Warranty 16  
weight 12